



APPLICATION GUIDE.

Rayston Proof PU Green Roof System

by Krypton Chemical

Contents

1. General conditions	3
2. Proposed solution	4
3. System steps.....	4
4. Requirements of the substrate and treatment of details and specific points.....	5
5. Steps and application of the system	10
5.1 Primer.....	10
5.2 Main membrane.....	11
5.3 Final layer	11
6. Certificates	12
7. Maintenance.....	12
8. Conclusions	13

1. General conditions

RECOMMENDATIONS

MANUFACTURER

The manufacturer of the products used in the work described in this specification shall demonstrate in writing that its Quality Assurance system complies with the requirements of Spanish Standard UNE-ISO 9001.

APPLICATOR

For the correct application of the systems specified in this report, it is recommended that the application company has successfully completed a training program on their installation or application and the appropriate methods for preparing the substrate. It must also have the necessary equipment for the correct application of the product. The application company must have the necessary means and equipment in suitable condition for the correct application of the system.

EXECUTION OF THE APPLICATION:

ENVIRONMENTAL CONDITIONS

Before starting the work described in this specification, check that the environmental conditions, the site, and the substrate are suitable for application.

The final responsibility for any decision regarding the application of the system on site shall lie with the site manager, project manager, and/or builder, and in no case with the product supplier.

PREPARATION

Proper preparation of the substrate is vital for the correct application of the products. Therefore, the technical instructions recommended by the manufacturer must be followed.

APPLICATION

It is recommended that the products described in this report be applied or installed in accordance with the manufacturer's instructions and in compliance with current regulations.

PROTECTION SYSTEMS

Before starting the application work, the necessary measures must be taken to protect workers in terms of occupational risk prevention, and appropriate measures must be taken to ensure that personnel not involved in the work are not affected by the application.

2. Proposed solution

This document is intended to assist you and the applicator during the application of the **RAYSTON PROOF PU GREEN ROOF** system. High-performance liquid waterproofing system, applied cold to concrete. Specific system for green roofs.

To this end, the preliminary actions to be carried out on the surface must be defined in order to mitigate the risk of future injuries. In addition, we will take into account the minimum properties that the substrate must meet in order to mitigate future risks.

3. System steps

The system must follow these steps:

- Primer: Rayston Epoxy 100.
- Main membrane: Impermax reinforced with Rayston Fiber 150.
- Geotextile.
- Drainage sheet.
- Geotextile.

[FT flashing](#)

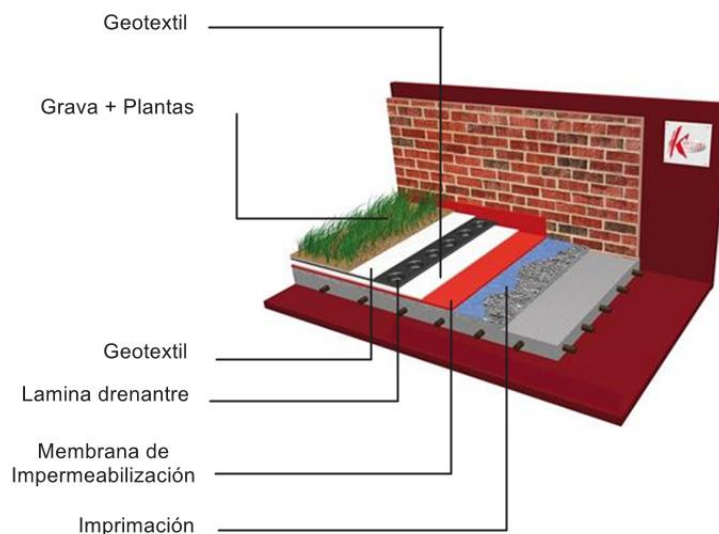

4. Requirements of the substrate and treatment of details and specific points

1 Substrate requirements

The concrete substrate must meet the following properties:

- Compressive strength (minimum 25 N/mm²)
- Minimum cohesion (resistance to tearing/traction) of 1.5 N/mm².



- HR <4%
- No cracks
- Cohesive
- Uncontaminated
- Level

(Otherwise, the coating will highlight any existing irregularities)

2 Moisture content, ambient temperatures, and substrate.

It is important to monitor ambient temperatures and humidity throughout the application cycle to prevent accelerated reactions.

The substrate must be as dry as possible.

Recommended ambient temperature conditions: Min. +10°C, Max. +30°C.

Always apply (each layer of the treatment) to a substrate whose temperature is 3°C above the dew point (to prevent condensation of ambient humidity on the substrate).

3 Substrate preparation:

To ensure good compatibility of the system with the existing substrate and to obtain good adhesion, it is very important that the substrate meets the minimum conditions and has the following properties:

1. Cohesive.
2. Regular and homogeneous.
3. Completely continuous.
4. Free of cracks, fissures, and cavities (which must be treated beforehand).
5. Clean and free of dust, grease, fluids, and any other type of chemical contaminant.
6. Completely cured.
7. Free of particles and other materials not completely adhered to the substrate.
8. As dry as possible (without risk of negative pressure).

The substrate must be washed with a high-pressure water jet to remove dirt (degreasing) and impurities. It is important that no material residues remain, as these can affect the adhesion of the membrane to the substrate.

The degree of roughness in the concrete must be CSP1-CSP3 according to Technical Guide No. 03732 of the ICRI (International Concrete Repair Institute) "Selection and Specification of Concrete Surface Preparation for Polymeric Coatings, Sealants, and Linings."

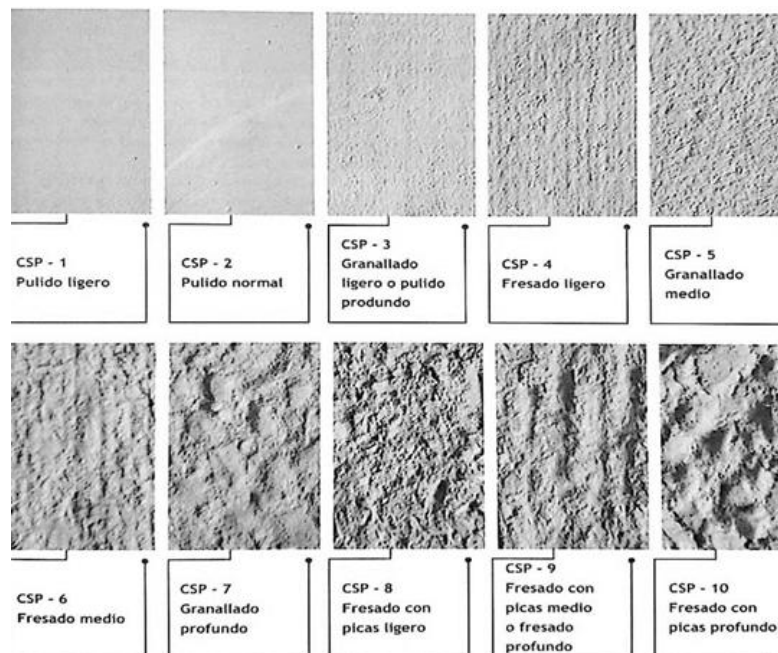

4 Treatment of damage and impact marks:

Before proceeding with the primer on the surface, local treatments will be carried out with dry mortar based on Rayston Epoxy 100 resin, with aggregate of 0.4 to 0.9 mm grain size or equivalent, or with R4-type cementitious repair mortar, ensuring complete aesthetic homogeneity with the existing treatment. Any cracks or small cavities will be filled with Rayston Flex polyurethane putty or equivalent.

5 Treatment of details and specific points:

Right angles should be avoided at horizontal-vertical joints, corners, and other parts of the structure; in other words, it is advisable to round off these areas of the surface with mortar (**half-rounds**).



To **prevent delamination** of the polyurethane membrane at the edges of the treatment, it should end about 15-20 cm from the floor on the vertical part. At this point, a groove will be cut with the help of a radial saw. The edge of the membrane will end inside this groove. This edge of the membrane must then be protected with a Rayston Flex-type polyurethane mastic. The installation of an aluminum protective profile will prevent possible detachment of the edge of the membrane in the medium and long term.

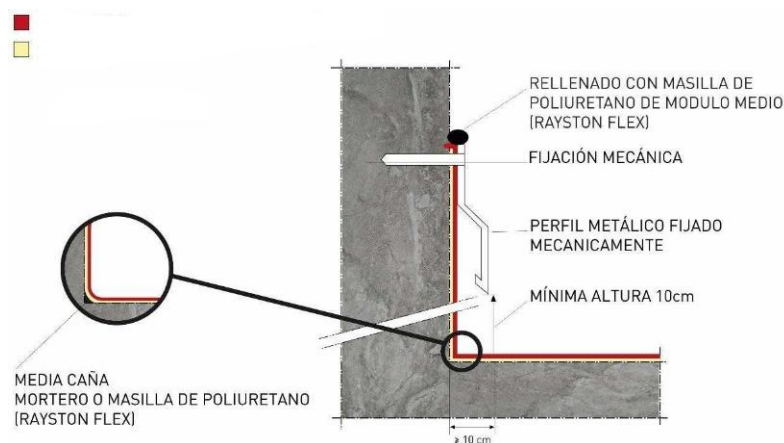

The following steps must be followed for **drains**:

1. Cut enough wedge-shaped reinforcement strips to cover the drain in overlapping layers.
2. Dip the individual strips in waterproofing resin, ensuring that each one is saturated.
3. Apply waterproofing resin to the top and inside of the drain, making sure that no resin drips down the drain.

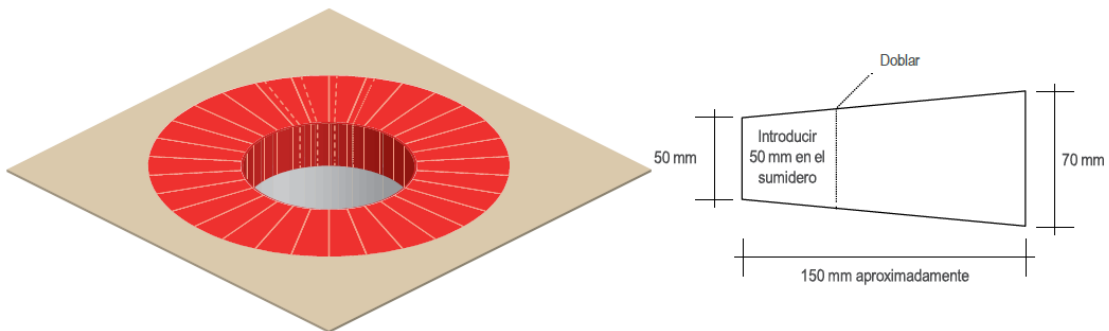

4. Remove any excess resin from the strips and place them in an overlapping pattern until the entire outlet is covered.
5. Remove any air bubbles or wrinkles and apply additional resin to the reinforcement (if necessary), taking care to peel back the overlapping edges.
6. Cut a square piece of reinforcement with rounded corners, cut a circular hole in the middle of the piece with a diameter = drain diameter + 20mm, and saturate it with waterproofing resin, then squeeze out the excess resin and place it over the drain, making sure the hole in the piece is directly over the drain.
7. Use a brush or roller to remove any air bubbles or wrinkles and to ensure that the square reinforcement piece is completely saturated and pressed down firmly.

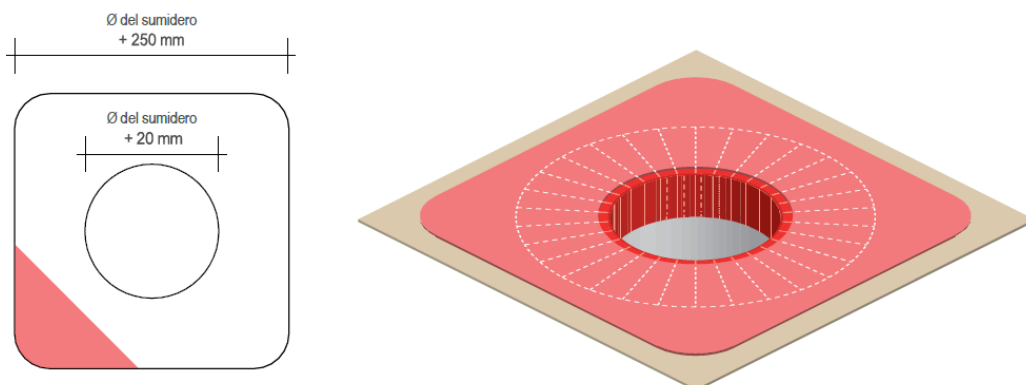

With regard to the **expansion joints** in the structure, if they have a movement greater than 50% of the size of the joint, mechanical joints must be installed (for example, a joint with a minimum width of 10 cm must be opened a maximum of 15 cm). To ensure the watertightness of the system, these mechanical joints must be installed following the manufacturer's specific recommendations.

If the movement is smaller, it can be treated with Rayston Joint Geo high elasticity tape, after filling it appropriately (polyethylene foam cylinder and Rayston Flex type polyurethane putty). Rayston Joint Geo adheres to the primed substrate thanks to an adhesive (2K PU Adhesive) or an epoxy resin such as Rayston Epoxy 100 applied to the geotextile attached to the tape. Polyurea membranes do not adhere well to Rayston Flex Joint Geo tape, so if the joint moves, this movement will not be transferred to the polyurea membrane, or in any case the movement will be attenuated when it reaches the polyurea membrane, reducing the risk of cracking.

Rayston Joint Geo can be supplied in different widths; it is advisable to always use a strip of the appropriate width.

For small jobs, Rayston Flex 3040 single-component polyurethane mastic should be applied manually. For greater productivity, the highly elastic polyurea-based mastic (two-component, cures in a few seconds) Rayston Flex 70 can be applied alternatively with the portable Rayston Spray Gun machine. If a large number of linear meters of joint need to be filled, application will be more efficient with the Rayston G-1 machine.

A similar treatment should be carried out on cracks larger than 2 mm or even smaller if there is a suspicion that they are moving and/or continuing to open over time (unstabilized cracks or fissures).

1. REGULAR, DRY AND FULLY CURED CONCRETE SURFACE.
2. JOINT BOTTOM: POLYURETHANE FOAM CYLINDER (PE).
3. RAYSTON FLEX 3040 / RAYSTON FLEX 70
4. PU 2K ADHESIVE OR RAYSTON EPOXY 100
5. RAYSTON FLEX JOINT GEO
6. SEPARATION STRIP (PE) - RAYSTON FLEX JOINT (OPTIONAL)
7. PRIMER
8. WATERPROOFING MEMBRANE APPLIED IN LIQUID FORM

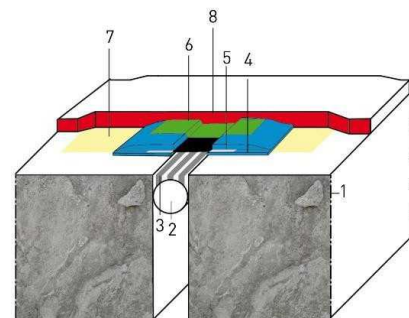

Important: Treatment carried out in winter (at the lowest possible temperatures) will always be more effective than treatment carried out in summer. In winter, at low temperatures, the materials will be contracted and the edges of the joint will be further apart. In summer, with high temperatures, the materials will be expanded and the edges of the joints will be closer together. If the treatment is carried out in summer, without leaving any slack in the membrane, when winter arrives and the environment cools down, the edges of the joints will separate and the membrane will become tense, with the risk of cracking.

5. Steps and application of the system

5.1 Primer

RAYSTON EPOXY 100 is a high-viscosity, high-solids epoxy system consisting of two pre-dosed components. Depending on the porosity of the substrate, it can be diluted with Rayston solvent to improve liquid penetration and adhesion performance. Ideally applied in two stages to achieve maximum adhesion.

Apply 0.5 kg/m² of Rayston Epoxy 100 in two coats. The first coat of primer can be diluted with 10%-15% Rayston Solvent to help it penetrate (anchor) into the surface and aid consolidation. A total of 0.2 kg/m² will be applied in this first coat.

Once the first coat has cured, apply the second coat with a light wet sprinkling of 0.3-0.8 mm aggregate. Apply a total of 0.3 kg/m².

For application, the material should be spread evenly, avoiding accumulations, and work within the product's shelf life (see FT).

Important: The primer is applied to seal the porosity of a surface and should never be applied when there is rising air, i.e., when there is direct sunlight on a porous exterior surface that is gradually heating up. The product recommended in this system, RAYSTON EPOXY 100, can only be used if the substrate moisture content is less than 4%. (If it is higher, ask the technical office for a list of primers).

Application tools Rayston Epoxy 100:



5.2 Main membrane

Impermax is a single-component liquid waterproofing system. It can be applied with a trowel, roller, brush, or airless spray gun. The product should be applied at a total rate of 2 kg/m² in two coats of 1 kg/m² each.

While the first coat is still fresh, apply Rayston Fibre 150 reinforcement. It must be completely embedded in the resin.

Once the first coat has dried, apply the second coat of Impermax (approximately one coat every 24 hours, or sooner depending on weather conditions). Use a spiked roller immediately after application to avoid bubbles. Impermax is an aromatic resin, which will turn yellow (depending on the color) quite quickly if exposed to sunlight.

A non-woven **geotextile** (200-500 g/m²) must be placed once the last layer of the main membrane has cured to protect it.

5.3 Final layer

Next, we will install a **drainage sheet**. In dry climates, Krypton Chemical, S.L. recommends Bio Roof Drain, which allows water (from rain or dew) to remain in the small bowls. The non-perforated version is even better for very dry climates.

Once the drainage sheet has been laid, protect it with a non-woven **geotextile** (200-500 g/m²).

The soil, free of sharp stones or edges, is poured onto this geotextile.

It is recommended to lay the drainage sheet and geotextile as soon as possible after applying Impermax.

6. Certificates

Impermax ST/QC

ETE certificate for roof waterproofing number 06/0263 dated 09/14/2018, issued by the Torroja Institute, the reference laboratory for construction products in Spain. The certificate lists several systems with different performance levels. The performance levels of the system proposed in this document are W3, S, and P4 to TH3 (above the minimum requirement of P4 to TH2).

British BBA (UK) certificate for roof waterproofing number 11/4836.

Performance in an external fire Broof(t1) and Broof(t4), with Broof(t4) being much more demanding than Broof(t1) and Broof(t1) being the minimum required by the CTE in Spain for roof coverings.

Certificate of resistance to root penetration according to Spanish standard UNE-53420.

7. Maintenance

It is advisable to maintain the facilities and carry out periodic cleaning, removing surface debris and dirt before cleaning.

A minimum frequency of two visual inspections per year is recommended, one at the beginning of spring and the other at the beginning of fall.

In addition, the roof should always be inspected after other professionals have carried out work such as construction, installation of new equipment, or repair of existing equipment.

8. Conclusions

The **RAYSTON PROOF PU GREEN ROOF** system proposed by Krypton Chemical has been used in a large number of construction and roof renovation projects in Spain and other countries. It has a long track record of success.

This system is completely continuous (without joints), remains adhered to the treated surface, and offers great resistance over time. In addition, it is a system that easily and effectively resolves all the unique issues that may be encountered in an installation of this type.

This system, applied on site by a company approved by Krypton Chemical, has CE marking based on tests carried out by the APPLUS laboratory.

The proposed system will improve performance, appearance, and aesthetics in the long term.

The information contained in this document, as well as the advice given by the professionals at Krypton Chemical, SL, whether in writing, orally, or through testing, is provided in good faith based on our experience and the results obtained through tests carried out by independent laboratories. However, it does not serve as a guarantee for the applicator, who should take it as a reference only and for informational purposes. We recommend that you study this information in depth before proceeding with the selection, use, and application of any of these products. It is advisable to carry out tests "in situ" to determine the suitability of a treatment on site. Our recommendations do not exempt the applicator from the obligation to have in-depth knowledge of the correct method of application of these systems before proceeding with their use, as well as to carry out as many tests as necessary in case of doubt about their suitability for any work, installation, or repair, taking into account the specific circumstances in which the product will be used.

Krypton's obligations are those established by Law 38/1999 on Building Regulations in Article 15 in its capacity as a product supplier. Under no circumstances is it assumed that Krypton is assuming the responsibilities and obligations corresponding to the site manager, construction manager, and builder as established by said law. The obligations enforceable against Krypton shall only be those that can be claimed from a product supplier. Under no circumstances, through this or any other document, does Krypton assume the responsibilities and obligations corresponding to the project manager, the construction manager, or the builder.

KRYPTON CHEMICAL S.L.

Pol. Industrial Les Tàpies. c/ Martí i

Franquès 10-12 43890 L'Hospitalet de l'Infant

- Tarragona - Spain

+34 977 822 247

rayston@kryptonchemical.com

www.kryptonchemical.com

